

The ED250 range of switches have been designed to provide a rapid means of disconnecting batteries or other power supplies in the event of serious electrical faults. Whilst the switches are primarily intended for use with battery powered vehicles they are also suitable for use with static power systems. All types are capable of safely rupturing full load battery currents in the event of an emergency.

- Uninterrupted current - no or infrequent load switching requirements (maintains a lower contact resistance).

The ED250 is a manually operated device with an over-centre spring mechanism which provides a snap action for both opening and closing of the main contacts. The ED250 is easy to install (see drilling details) and is secured with supplied M5 posidrive mounting screws. Lockable versions feature a key which is necessary for the knob to be moved from the "Off" position to the "On" position. Once in the "On" position, the key can be removed. Thereafter, the knob may be depressed to the "Off" position where it will automatically lock and remain locked until the key is used again to unlock it. The ED250 is fully serviceable with genuine replacement parts available.

Precautions:

When fitted with magnetic blowouts the polarity marked on the contact housing must be observed when connecting the main terminals. Ensure that the switches are installed in a position where heavy arcs emanating from the switch cannot damage or electrically jump across to adjacent parts. The switch is to be used to rupture current in an emergency or as a no-load isolator.



ED250

Do not use as a regular On-Load Switching Device.

Application	Uninterrupted
Thermal Current Rating (I _{th})	250A
Intermittent Current Rating:	
30% Duty	455A
40% Duty	395A
50% Duty	355A
60% Duty	325A
70% Duty	300A
Overload Currents that can be Ruptured:	
ED250	1000A at 48V D.C.
ED250B	1000A at 96V D.C.
Maximum Recommended Contact Voltages (U _c):	
ED250	48V D.C.
ED250B	96V D.C.
Typical Voltage Drop per pole across New Contacts at 250A	30mV
Mechanical Durability	>10 x 10 ³ Cycles
Operating Ambient Temperature	-40°C to +60°C
Guideline Contactor Weight:	
ED250	450 gms
With Auxiliary	+ 20 gms
With Blowouts	+ 50 gms
With Lock	+ 60 gms

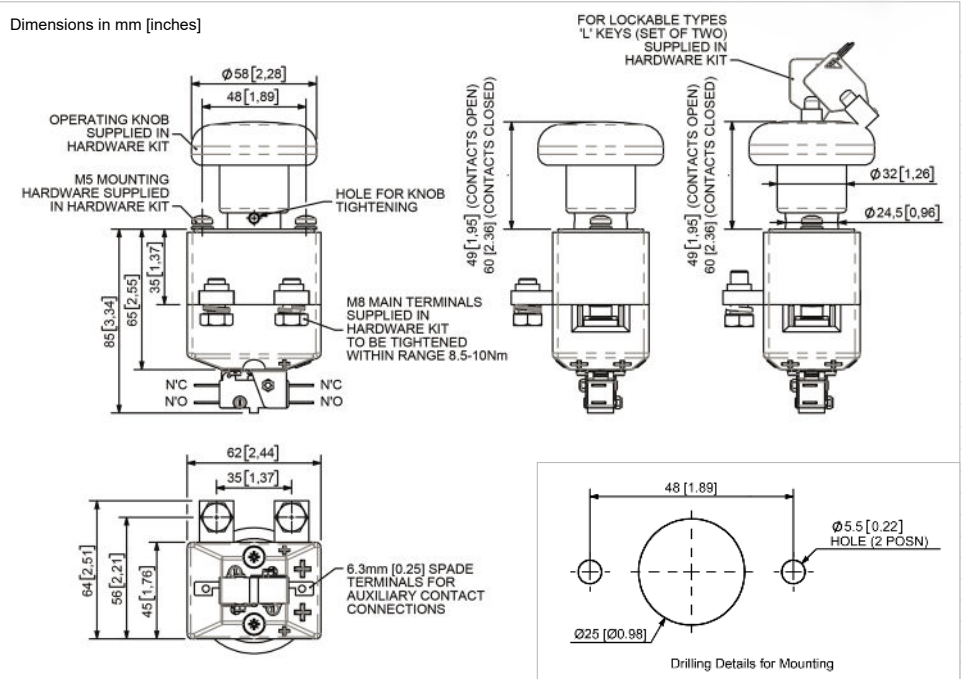

Auxiliary Details	
Auxiliary Thermal Current Rating	15A
Auxiliary Contact Switching Capabilities (Resistive Load):	
	15A at 24V D.C.
	10A at 48V D.C.
	5A at 96V D.C.
Advised Connection Sizes for Maximum Continuous Current	
Cable to be rated suitable to Application	
Key: ▲ = Uninterrupted	
Note: Where applicable values shown are at 20°C	

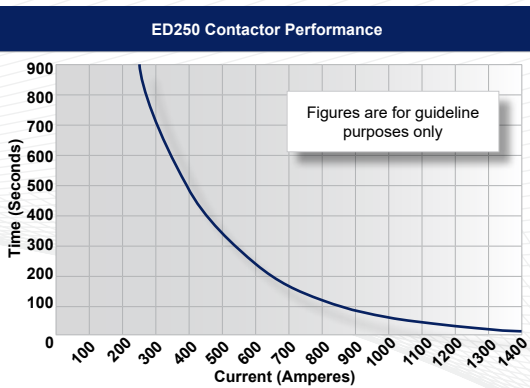

Contact Performance Key:

— Uninterrupted Current

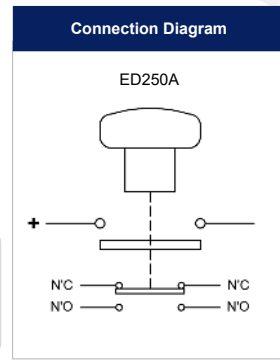

ED250 Available Options		
General		Suffix
Auxiliary Contacts	○	A
Auxiliary Contacts - V3	X	
Magnetic Blowouts†	○	B
Magnetic Blowouts - High Powered†	X	
Mounting Brackets	X	
Closed Contact Housing	○	
Environmentally Protected IP55‡	○	
EE Type (Steel Shroud)	○	
Lockable	○	L
Contacts		
Large Tips	X	
Textured Tips	○	T
Silver Plating	X	
Key: Optional ○ Standard ● Not Available X		
† Connections become polarity sensitive		
‡ A rubber gasket 'O' ring and special guide can be fitted to increase the sealing of the switch when mounted to the panel (uppermost section only)		

The Use of Battery Disconnecting Switches in Electric Vehicles

Modern battery powered electric vehicles are inherently very reliable and safe. However, even when sophisticated electronic controllers are used it is desirable to have a means of disconnecting the battery in the event of an emergency, such as a vehicle failing to stop or an electrical short circuit.

In many countries it is mandatory to fit one or more devices to achieve an emergency disconnection of the battery.

- Performance data provided should be used as a guide only. Some de-rating or variation from figures may be necessary according to application
- Thermal current ratings stated are Dependant upon the size of conductor being used
- Always make use of a Professional Installer.